

ELIAS Grammar Test

Kristin Kersten, Thorsten Piske, Andreas Rohde, Anja Steinlen, Martina Weitz
Pictures: Susanne Kurth



Early Language and Intercultural Acquisition Studies
Multilateral Comenius Project funded by the European Commission

Prompts

7. COPULAR VERBS

- i. A: **the deer is white**; the deer are white; distractor: the sheep (pl.) are white
B: **the deer are white**; the deer is white; distractor: the sheep (sg.) is white
- ii. A: **the fish is black**; the fish are black; distractor: the crabs (pl.) are black
B: **the fish are black**; the fish is black; distractor: the crab (sg.) is black
- iii. A: **the sheep is happy**; the sheep are happy; distractor: the cows (pl.) are happy
B: **the sheep are happy**; the sheep is happy; distractor: the cow (sg.) is happy

8. POSSESSIVE VS OBJECT

- i. A, B: **the girl is kissing the boy; the girl is kissing the boy's dog**; distractor: everybody in the picture, no action
- ii. A, B: **the girl is feeding the boy; the girl is feeding the boy's dog**; distractor: everybody in the picture, no action
- iii. A, B: **the girl is carrying the boy; the girl is carrying the boy's dog**; distractor: everybody in the picture, no action

9. PRO M/F SG

- i. A, B: **he is singing; she is singing**; distractor: everybody in the picture, no action
- ii. A, B: **he is drinking; she is drinking**; distractor: everybody in the picture, no action
- iii. A, B: **he is running; she is running**; distractor: everybody in the picture, no action

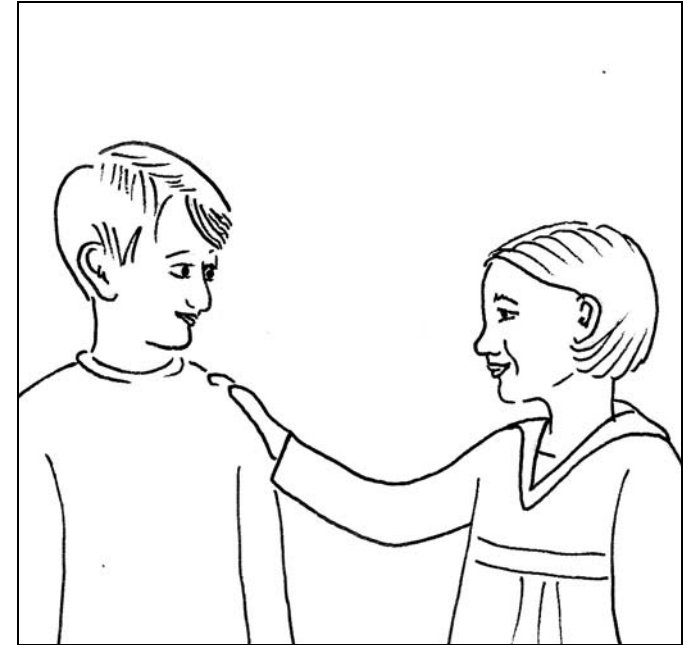
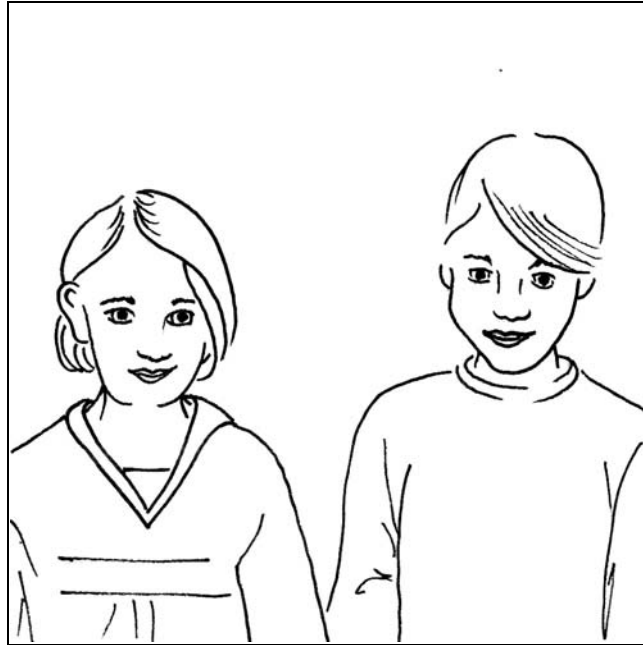
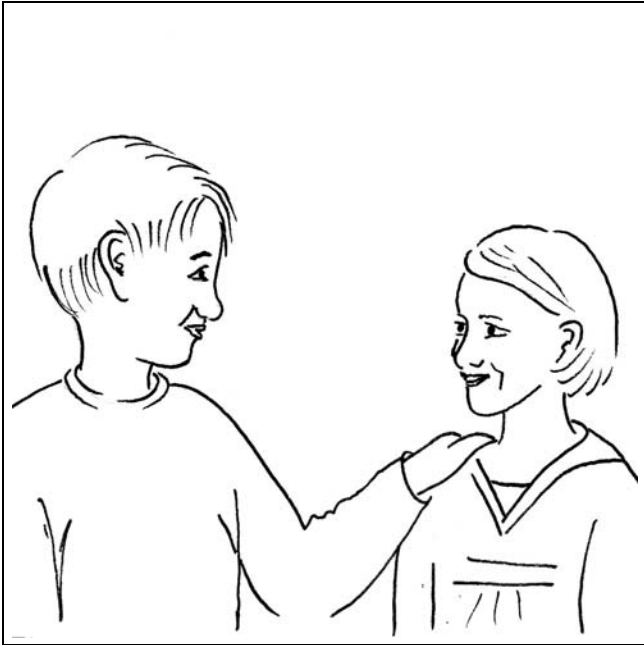

SVO 1.i A, B: **the boy is touching the girl; the girl is touching the boy**; distractor: boy and girl stand next to each other, no action

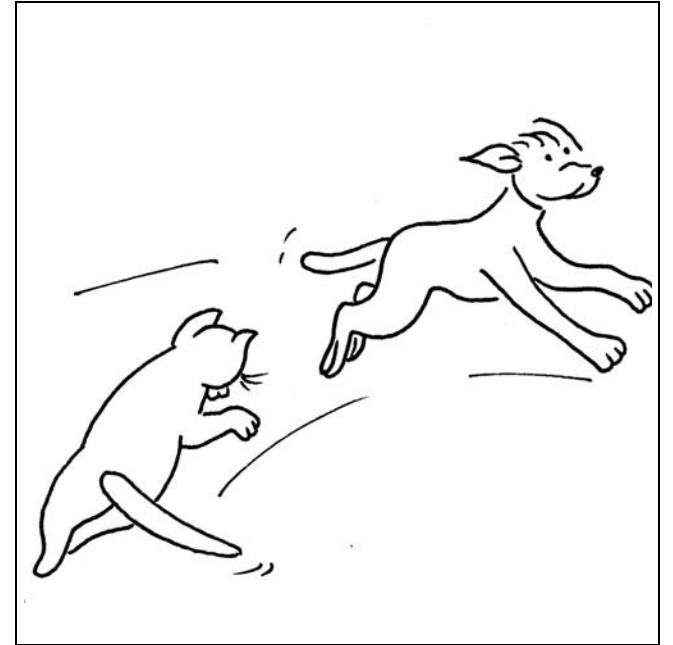
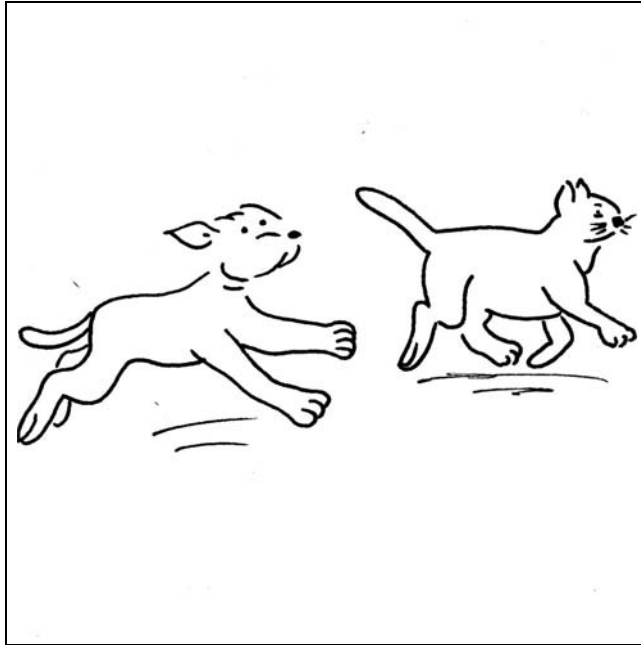
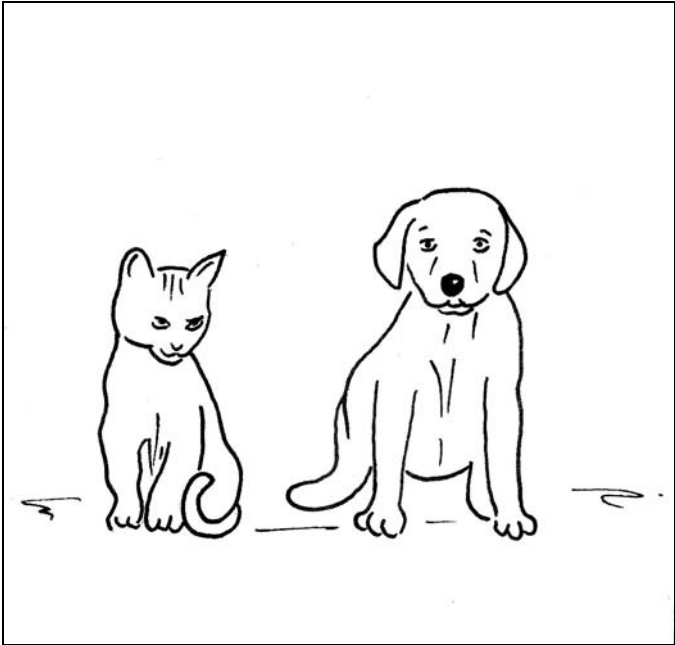

SVO 1.ii A, B: **the dog is chasing the cat; the cat is chasing the dog**; distractor: cat and dog sit next to each other, no action

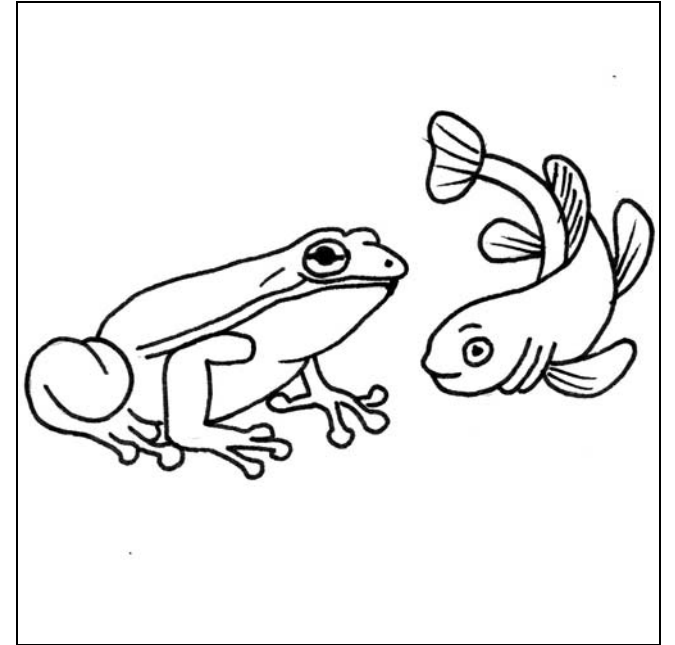
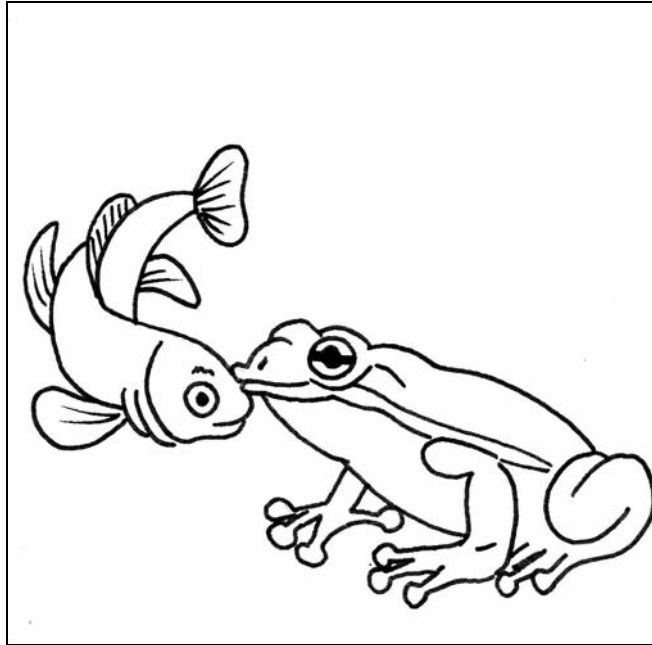
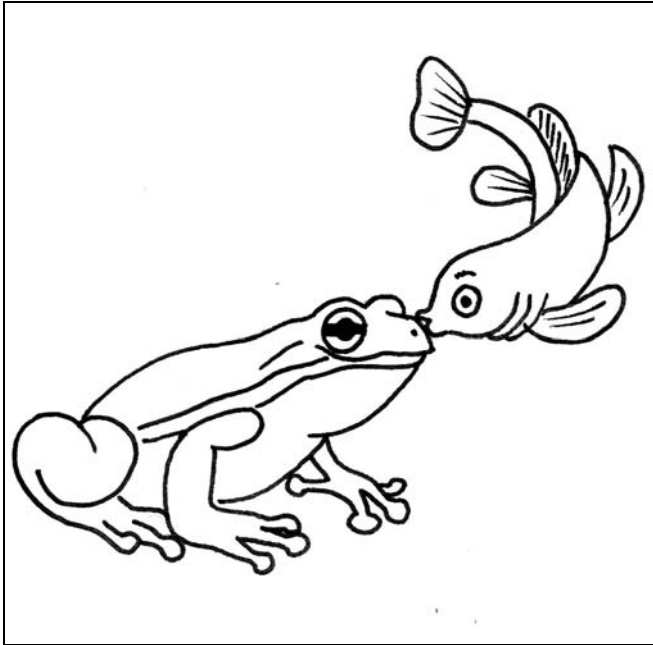

SVO 1.iii A, B: **the fish is kissing the frog; the frog is kissing the fish**; distractor: fish and frog stand next to each other, no action

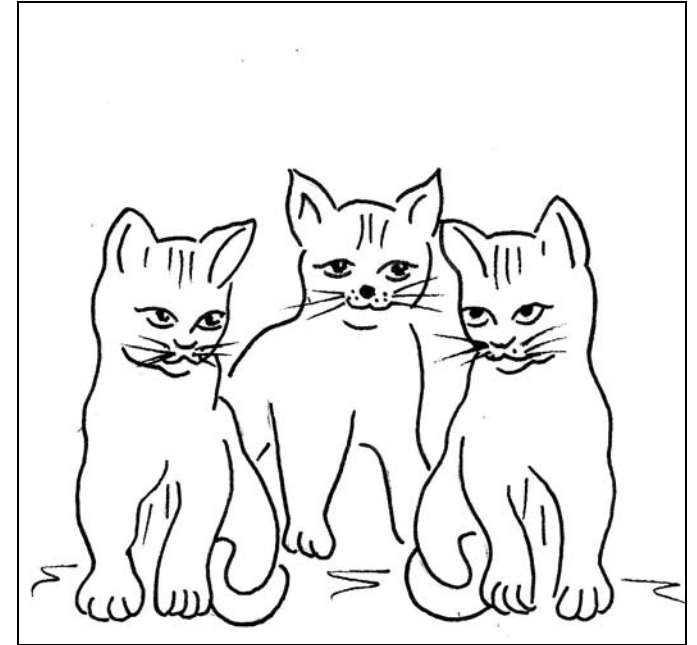
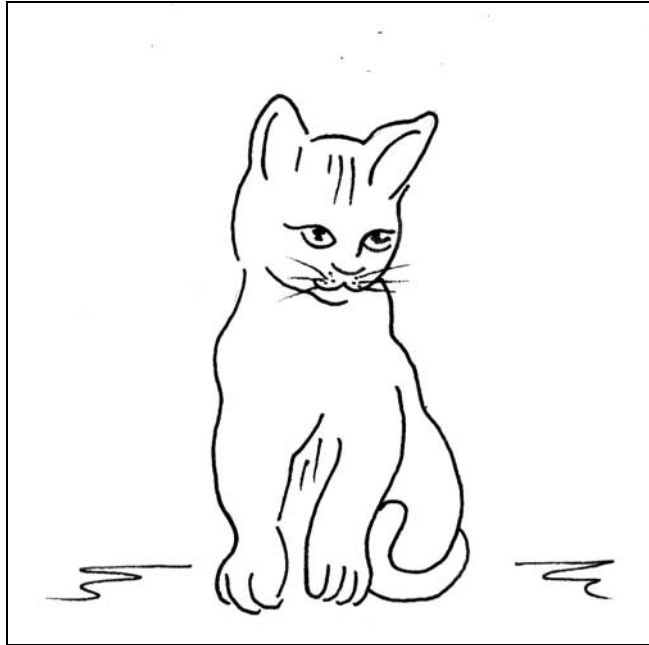
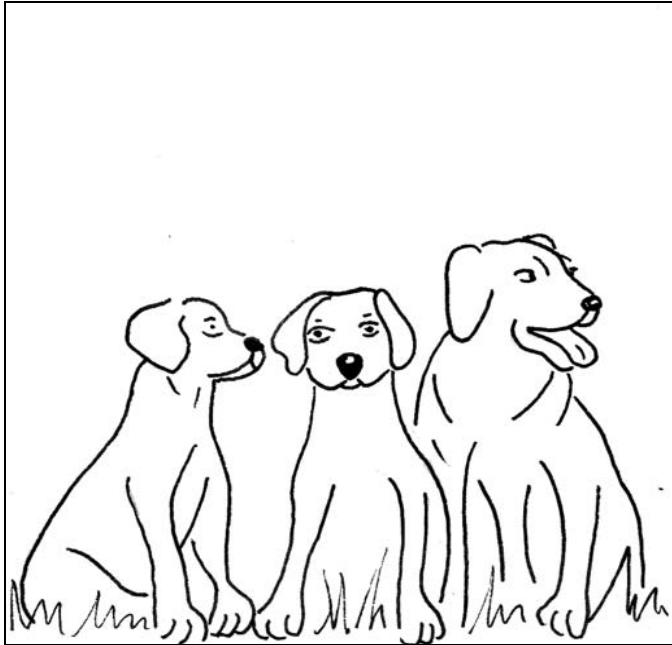

Plural -s 2.i A **cat**; cats; distractor: dogs

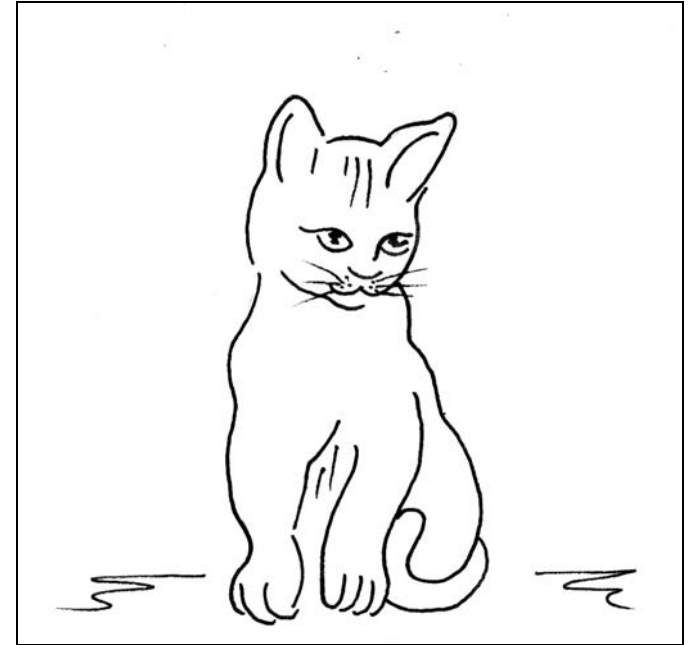
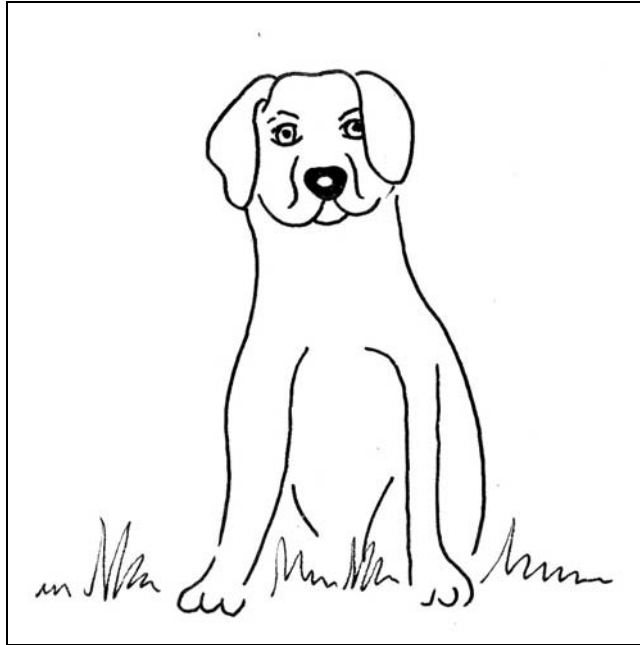
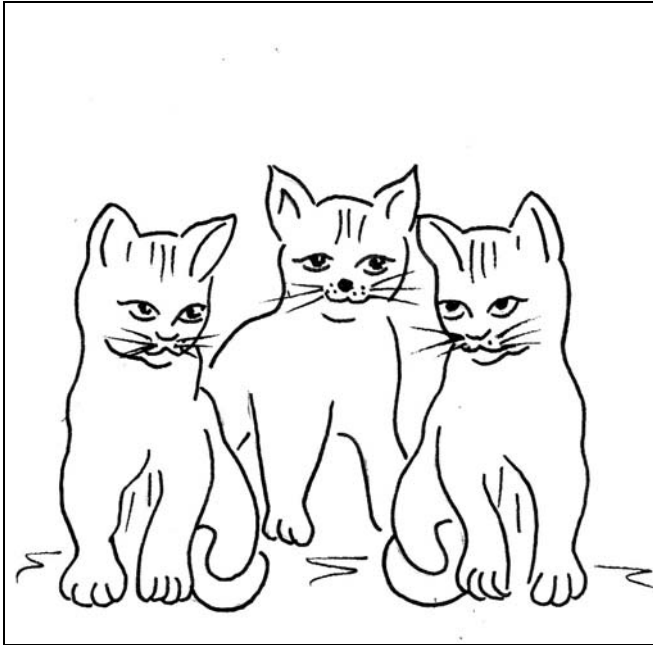

Plural -s 2.i B **cats**; cat; distractor: dog

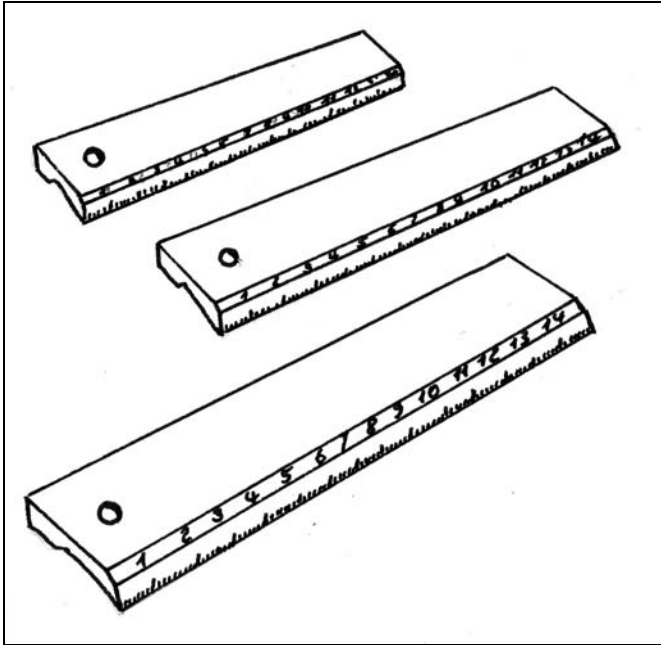

Plural -s 2.ii A **pen**; pens; distractor: rulers

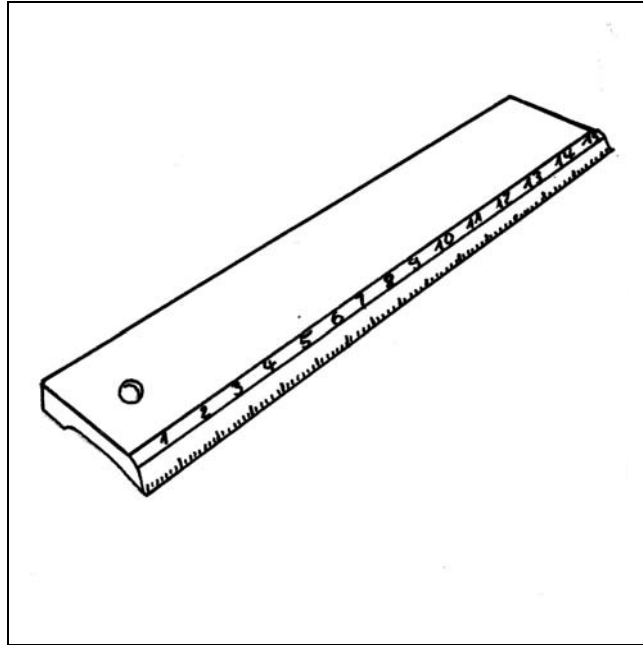

Plural -s 2.ii B **pens**; pen; distractor: ruler

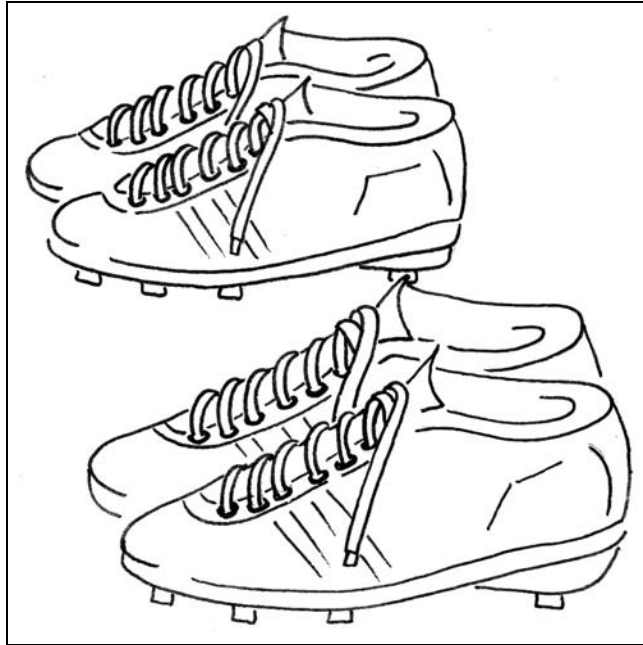

Plural -s 2.iii A **ball**; balls; distractor: football boots

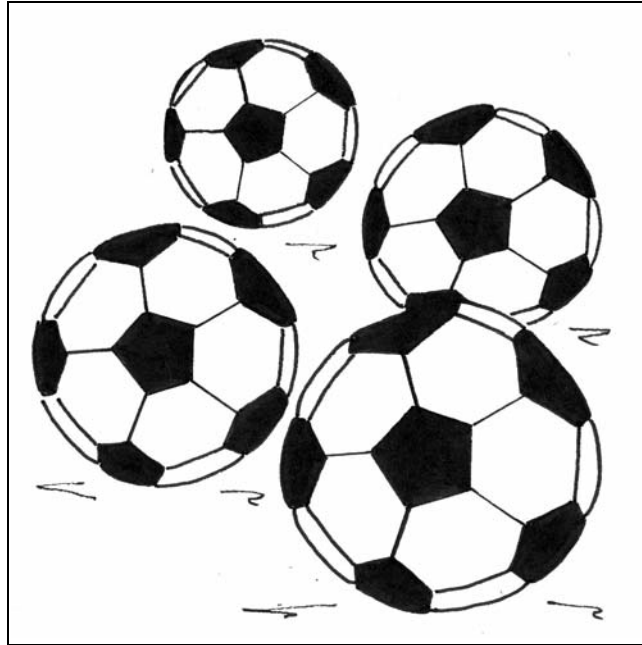
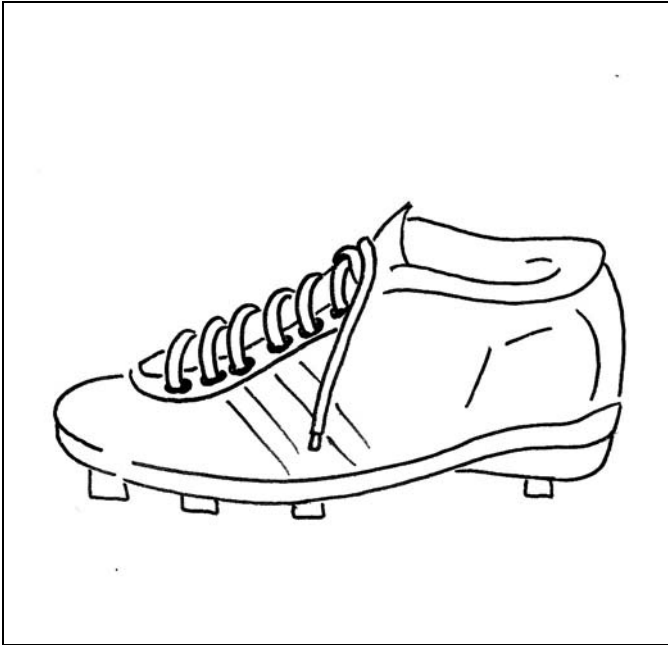

Plural -s 2.iii B **balls**; ball; distractor: football boot



Pro 3.i A, B: **the girl is kissing him; the girl is kissing her**; distractor: all three stand next to each other

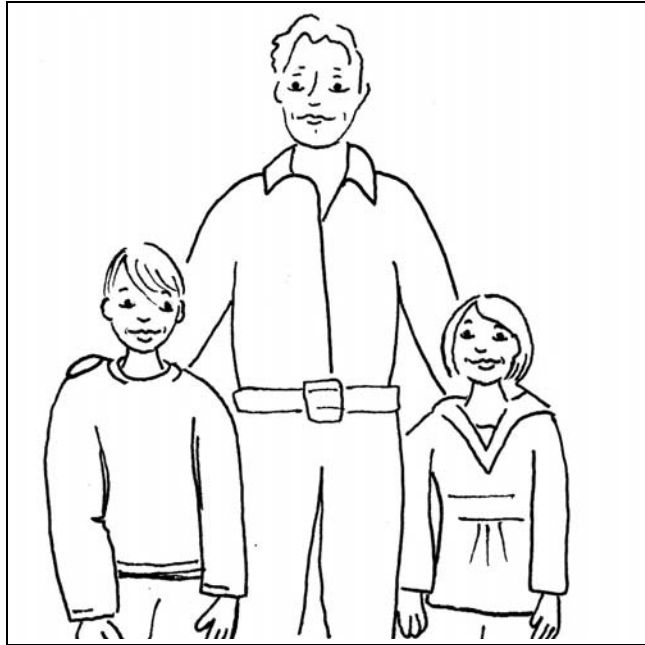
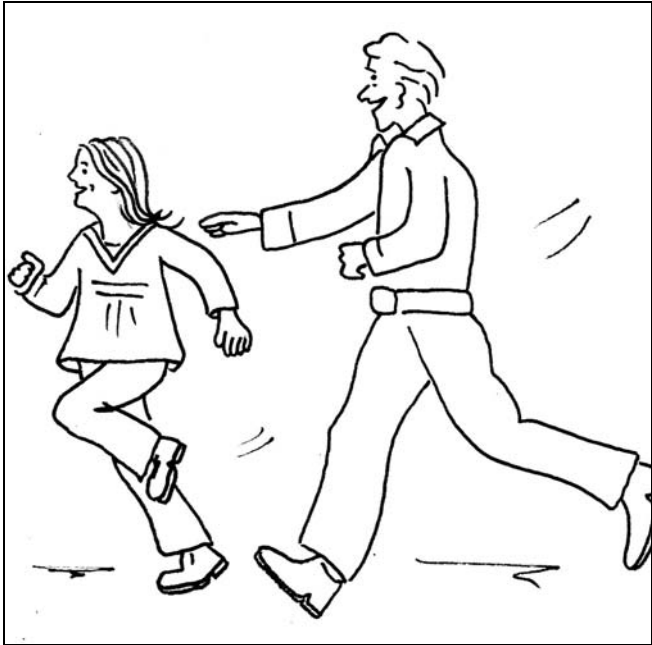

Pro 3.ii A, B: **the father is chasing him; the father is chasing her**; distractor: all three stand stand next to each other

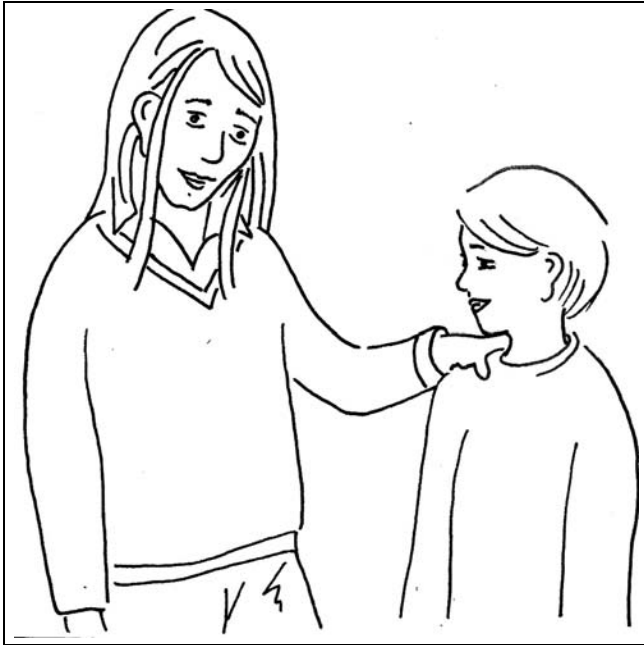

Pro 3.iii A, B: **the mother is touching him; the mother is touching her**; distractor: all three stand next to each other

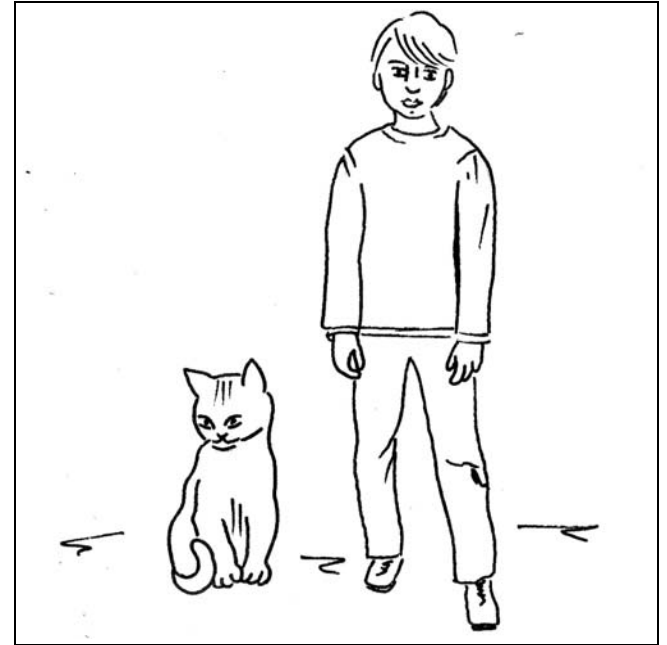
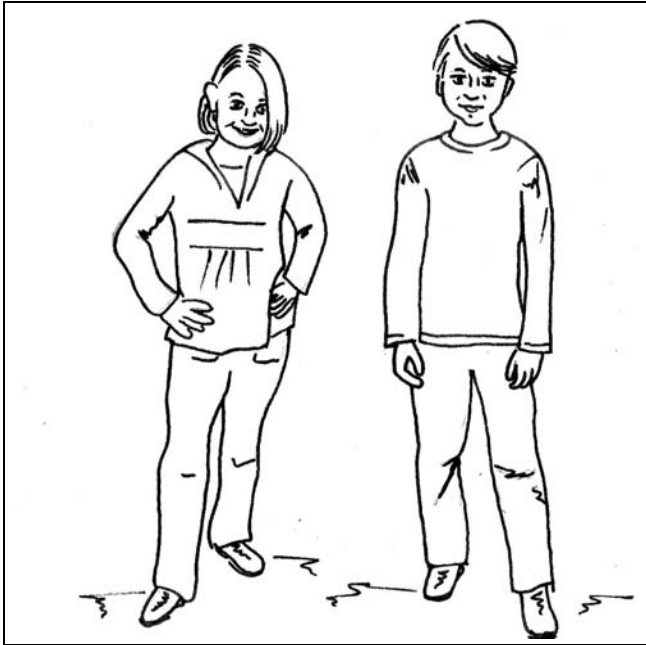

Poss Det 4.i A, B: **his cat**; **her cat**; distractor: both persons

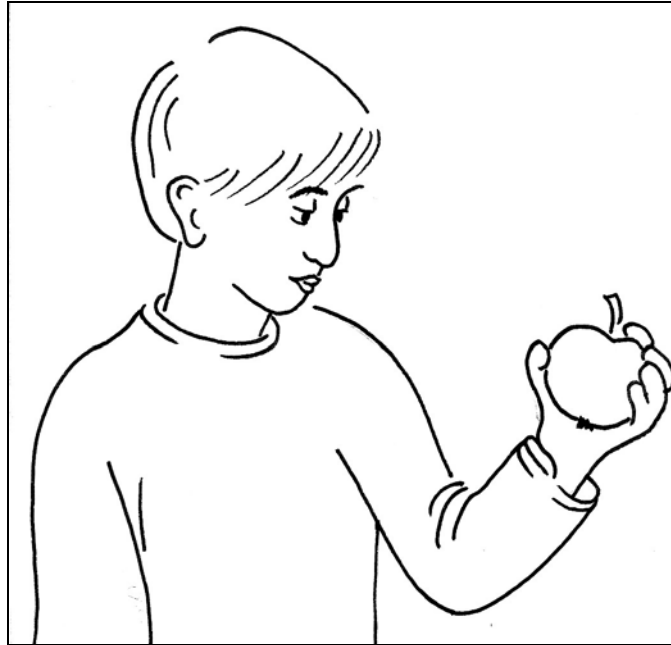
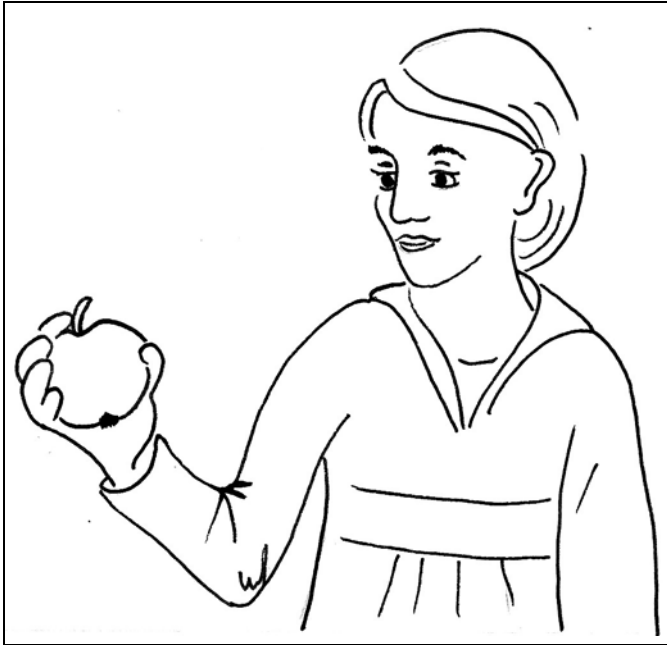

Poss Det 4.ii A, B: **his apple**; **her apple**; distractor: both persons

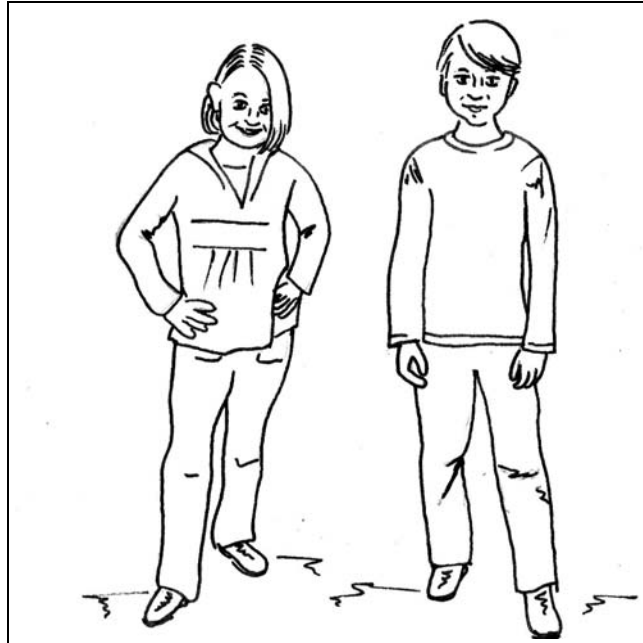

Poss Det 4.iii A, B: **his ball**; **her ball**; distractor: both persons



Neg 5.i A A: **the boy is running**; the boy is not running; distractor: the girl is not running



Neg 5.i B **the boy is not running**; the boy is running; distractor: the girl is running

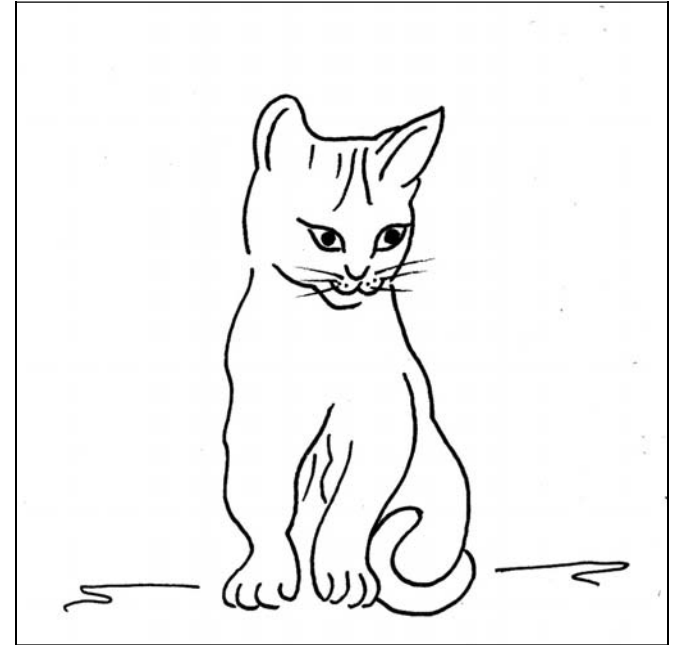
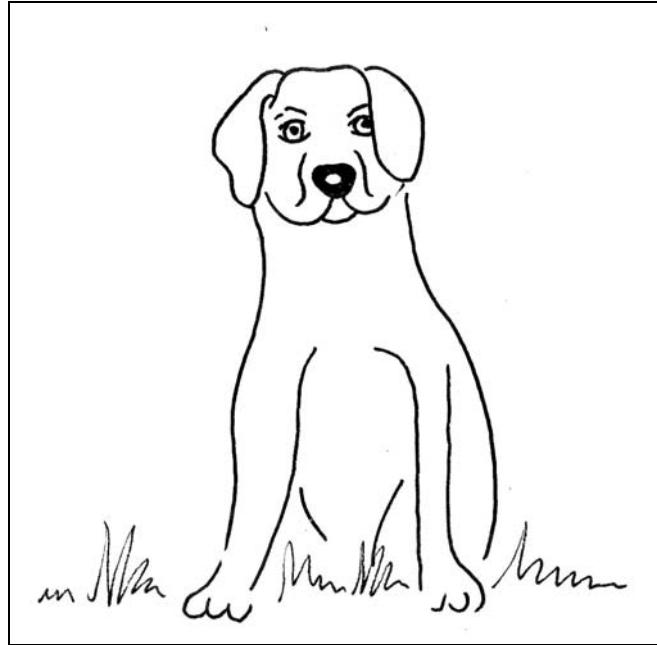
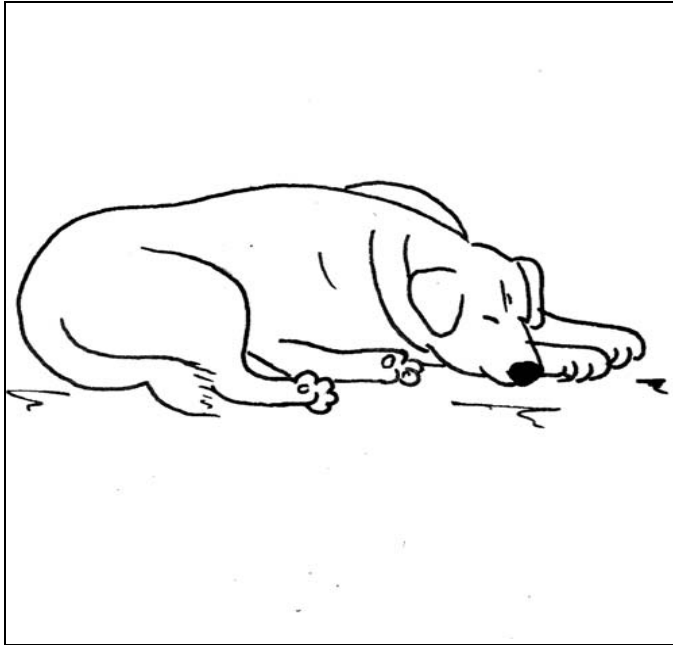

Neg 5.ii A **the dog is sleeping**; the dog is not sleeping; distractor: the cat is not sleeping

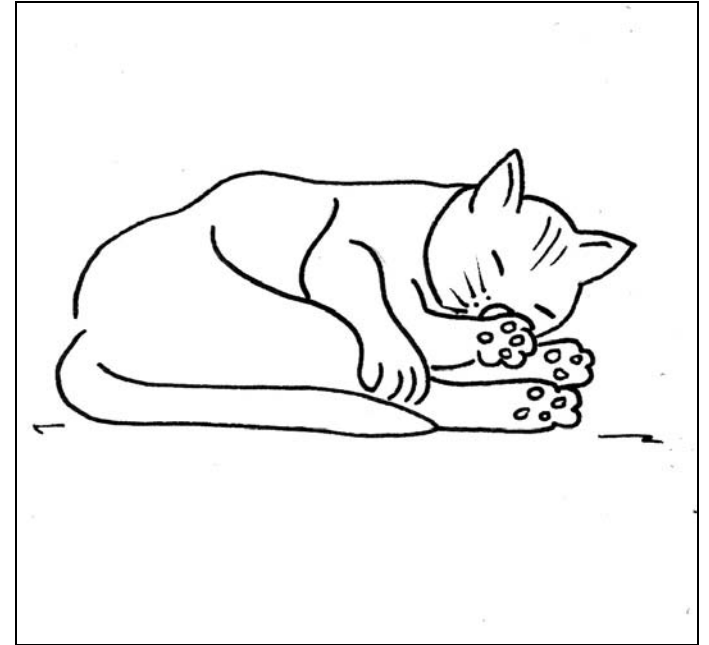
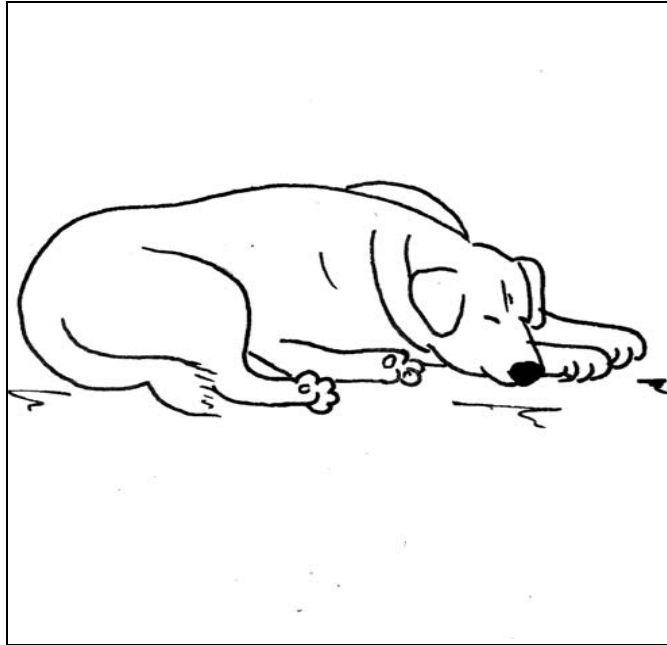
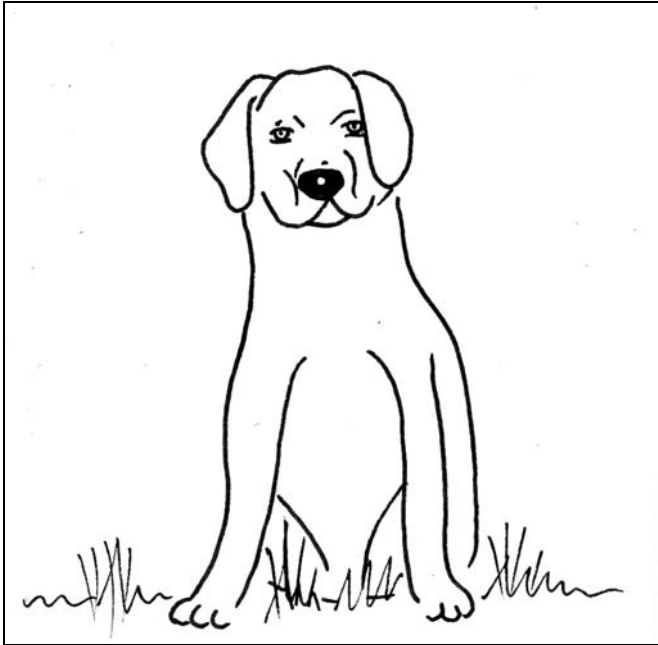

Neg 5.ii B **the dog is not sleeping**; the dog is sleeping; distractor: the cat is sleeping

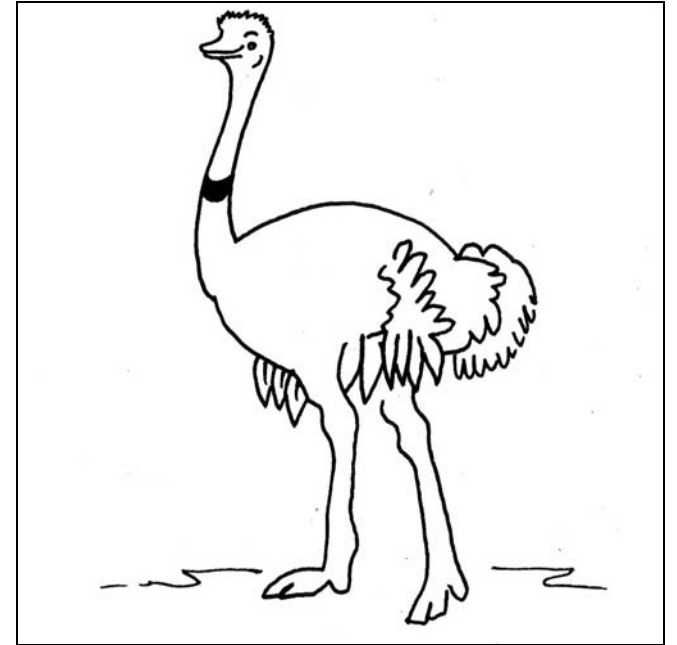
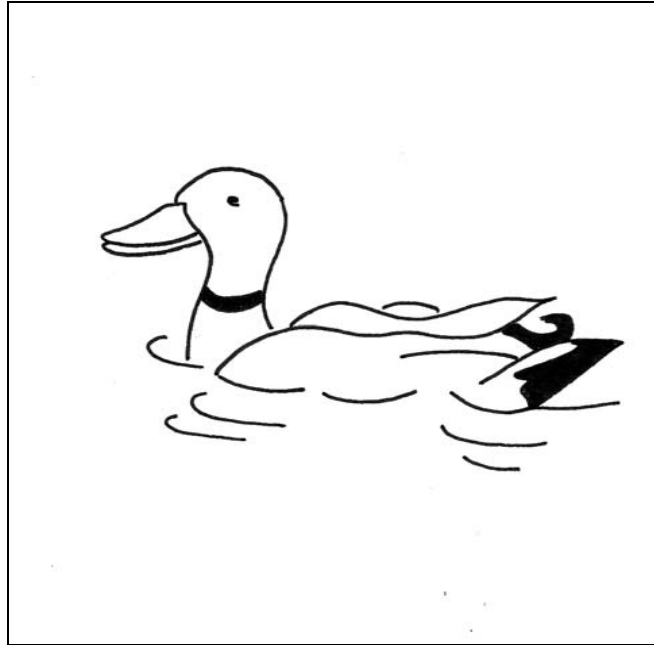
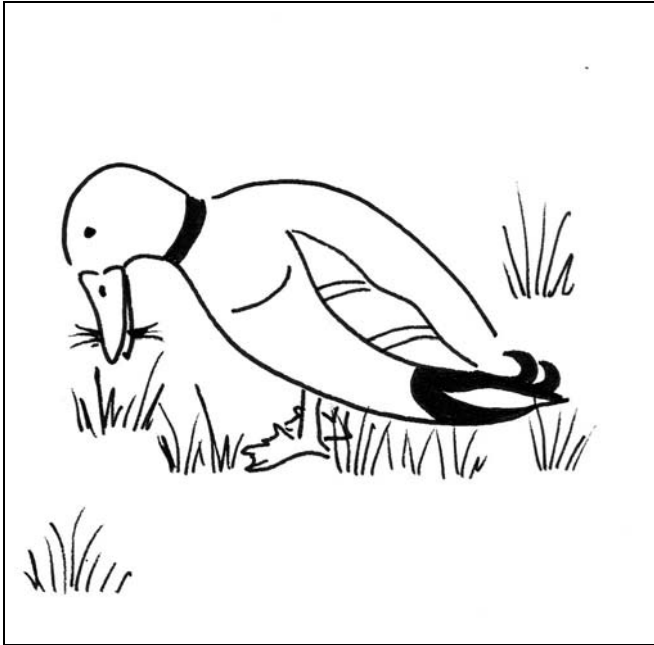

Neg 5.iii A **the duck is eating**; the duck is not eating; distractor: the ostrich is not eating

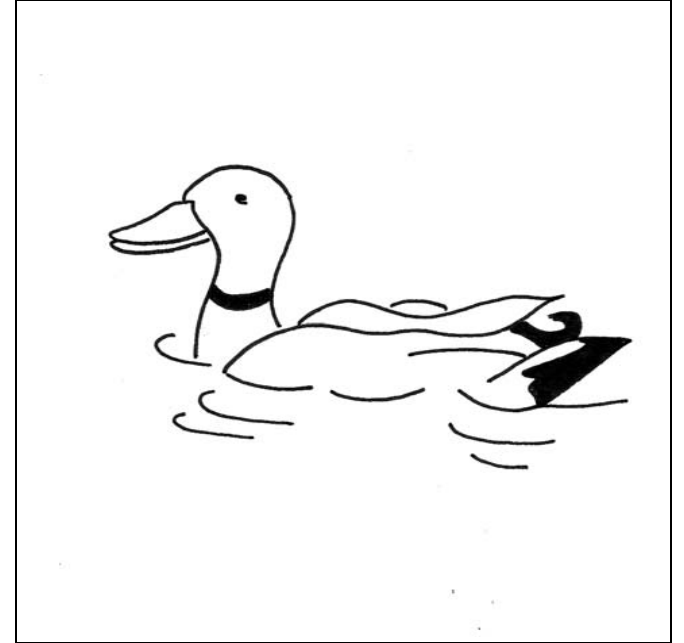
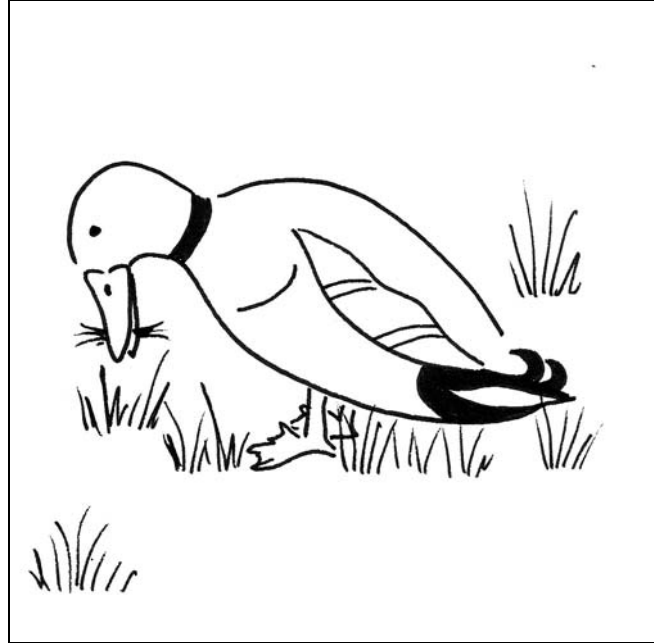
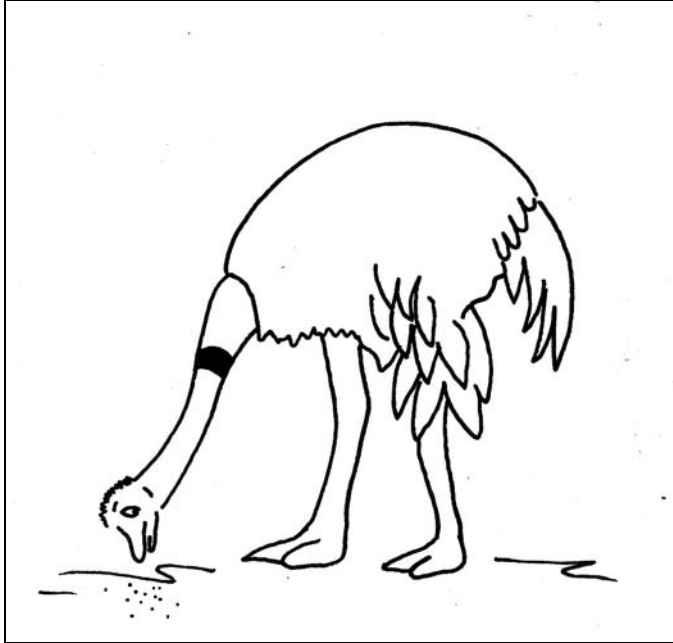

Neg 5.iii B **the duck is not eating**; the duck is eating; distractor: the ostrich is eating

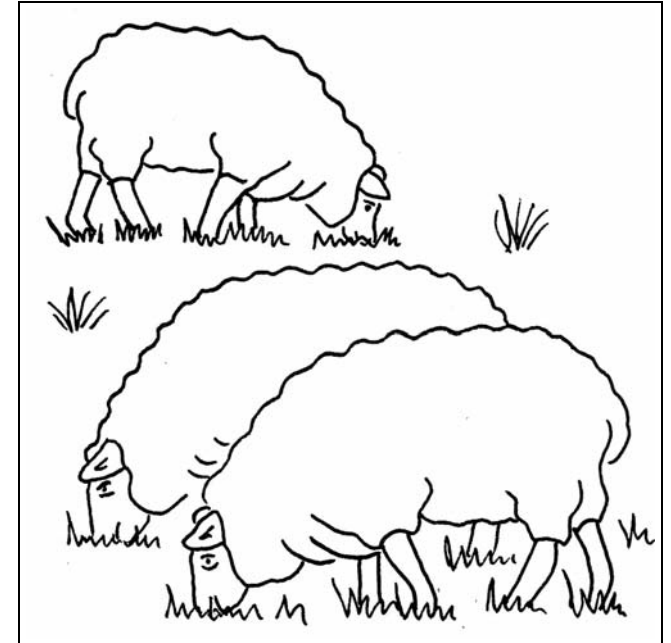
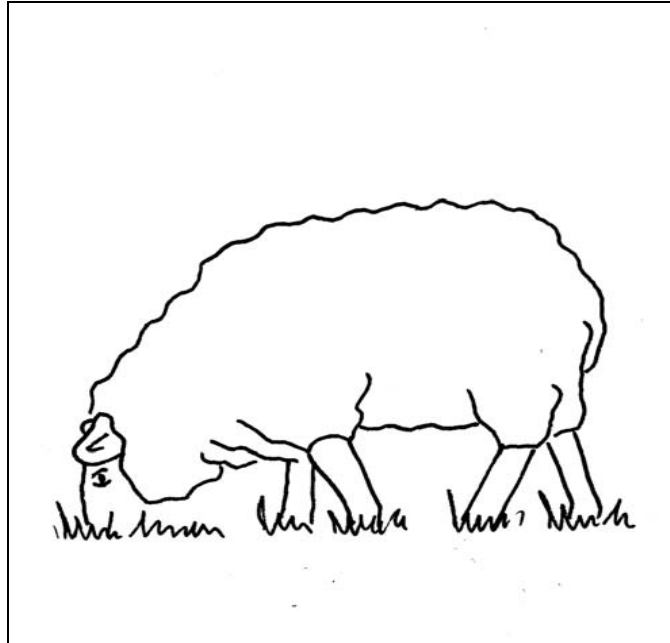
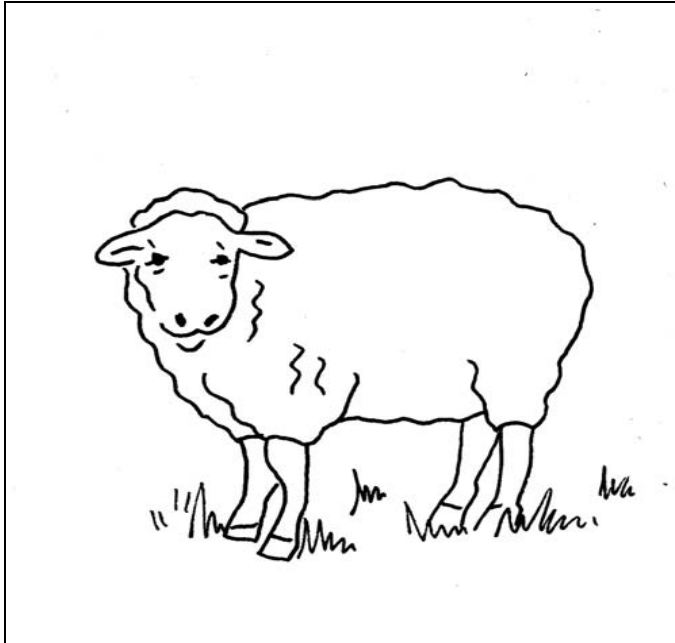

3. sg -s 6.i A **the sheep eat**; the sheep eats; distractor: sheep (sg.) no action

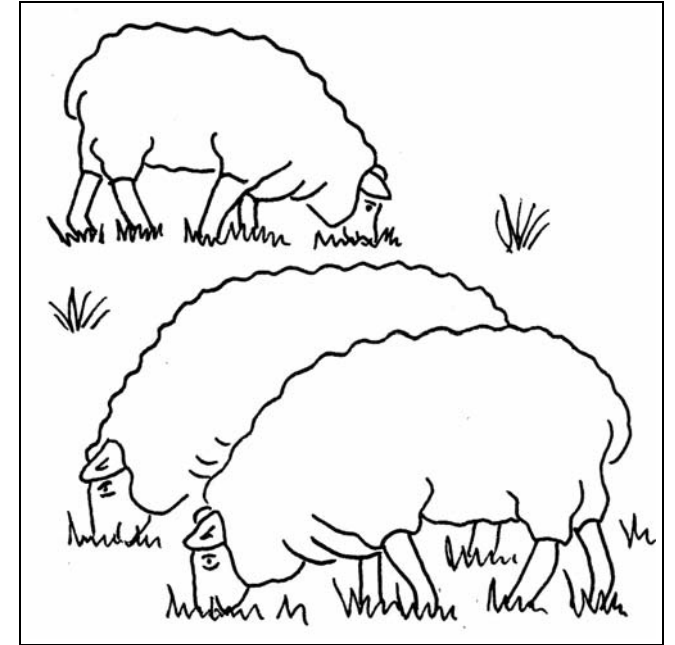
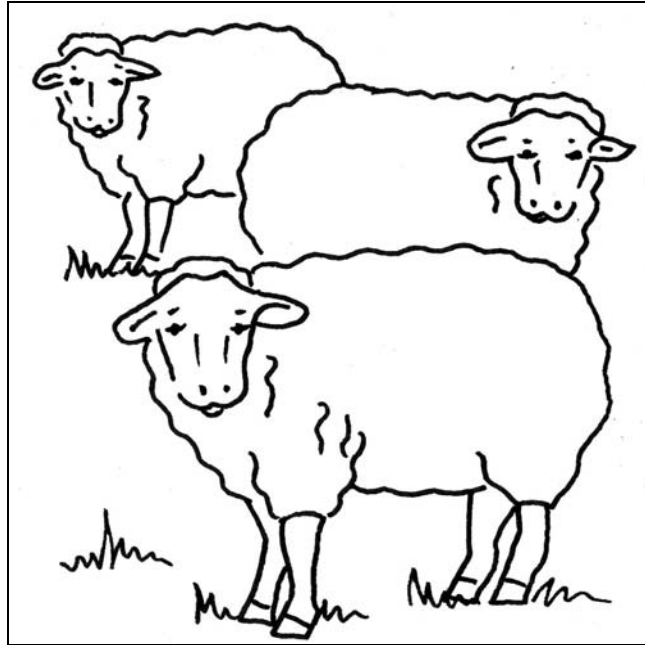
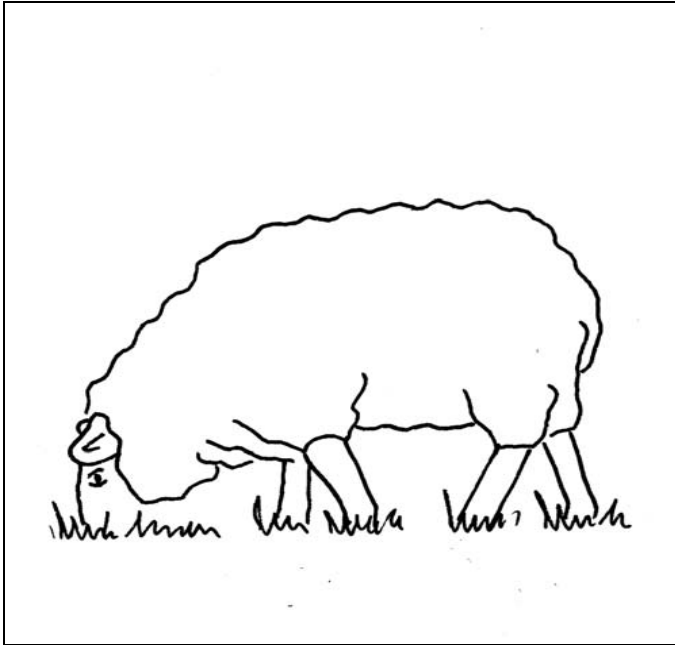

3. sg -s 6.i B **the sheep eats**; the sheep eat; distractor: sheep (pl.) no action

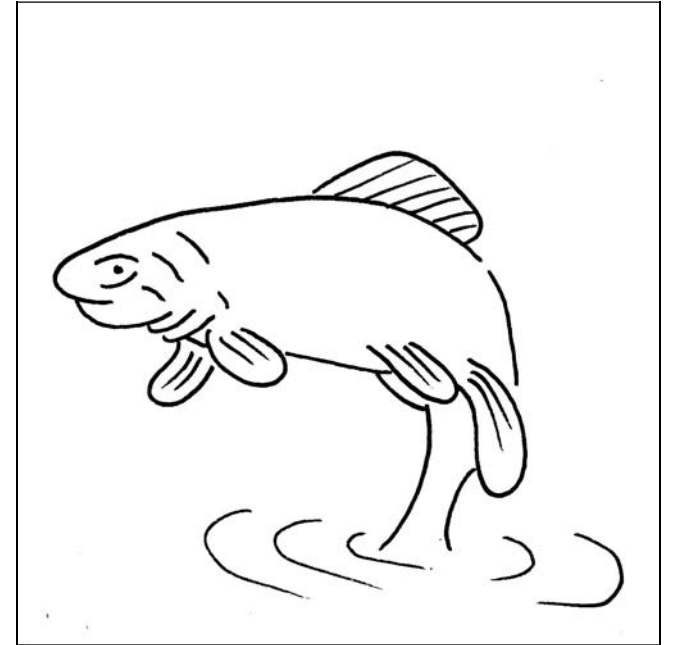
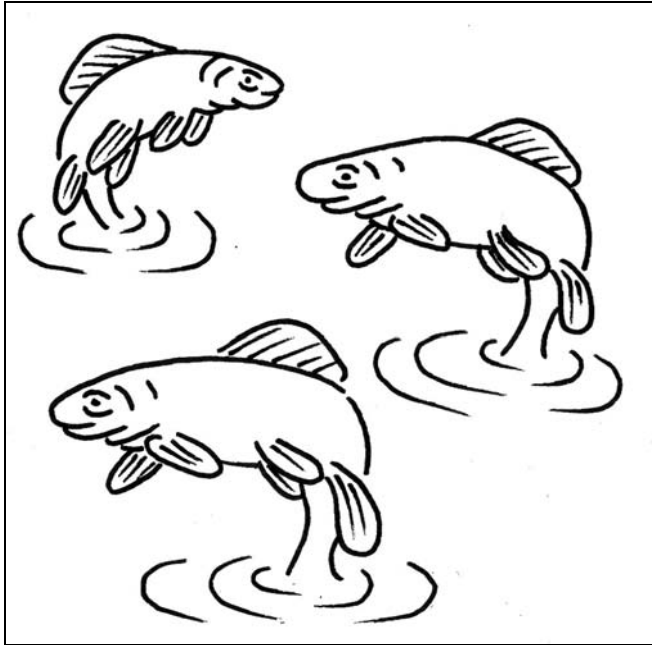
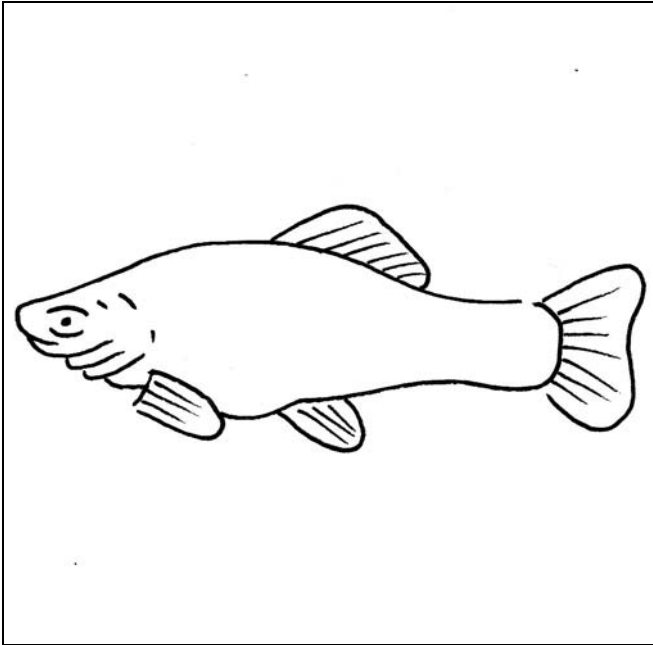

3. sg -s 6.ii A **the fish jump**; the fish jumps; distractor: the fish (sg.) no action

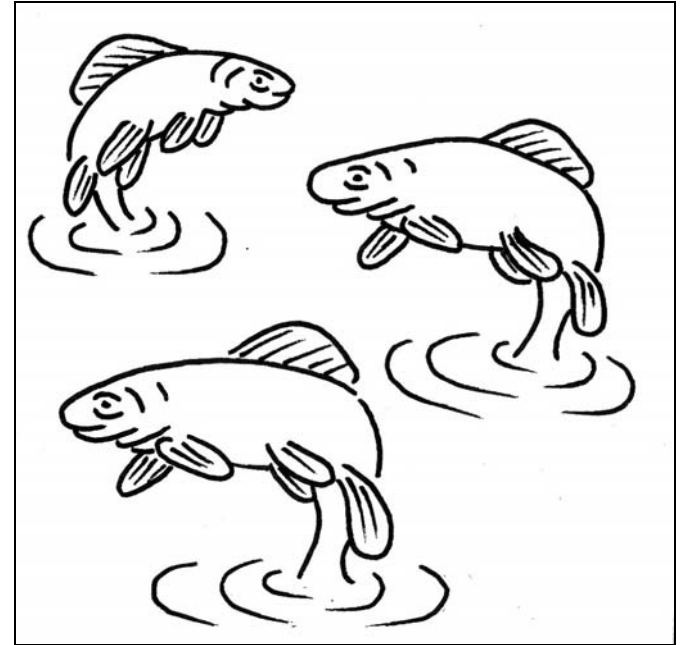
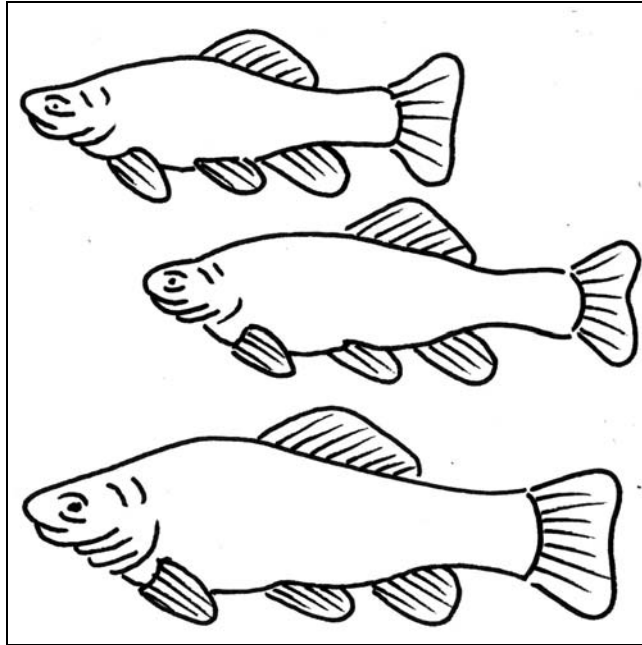
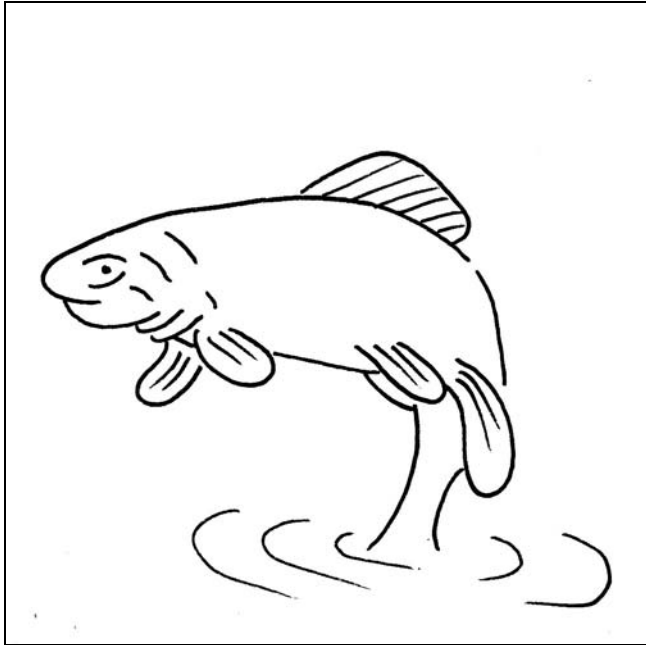

3. sg -s 6.ii B **the fish jumps**; the fish jump; distractor: the fish (pl.) no action

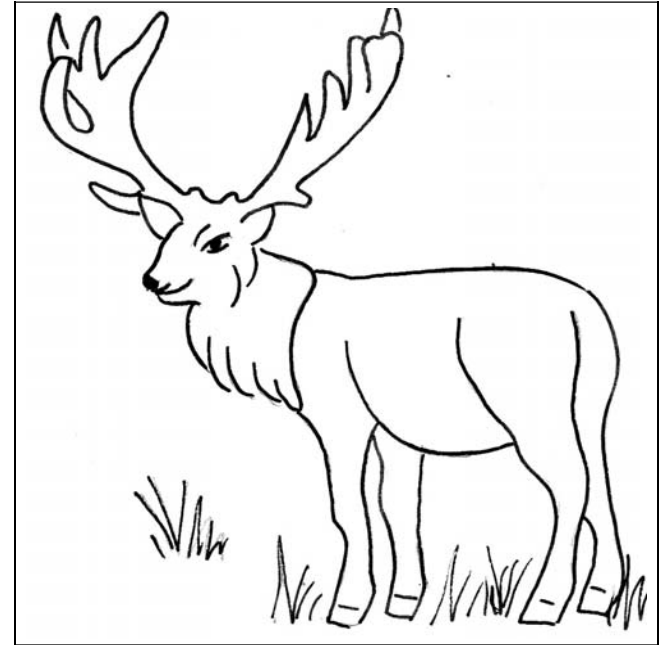

3. sg -s 6.iii A **the reindeer sleep**; the reindeer sleeps; distractor: the reindeer (sg.) no action

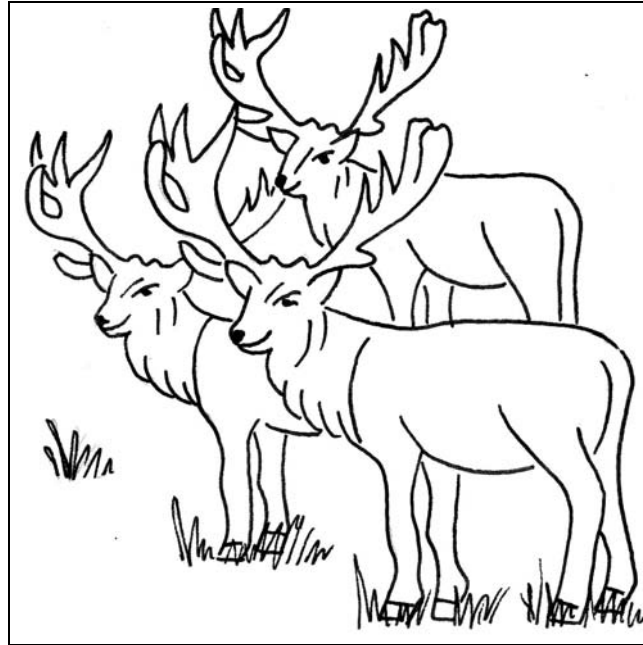

3. sg -s 6.iii B **the reindeer sleeps**; the reindeer sleep; distractor: the reindeer (pl.) no action

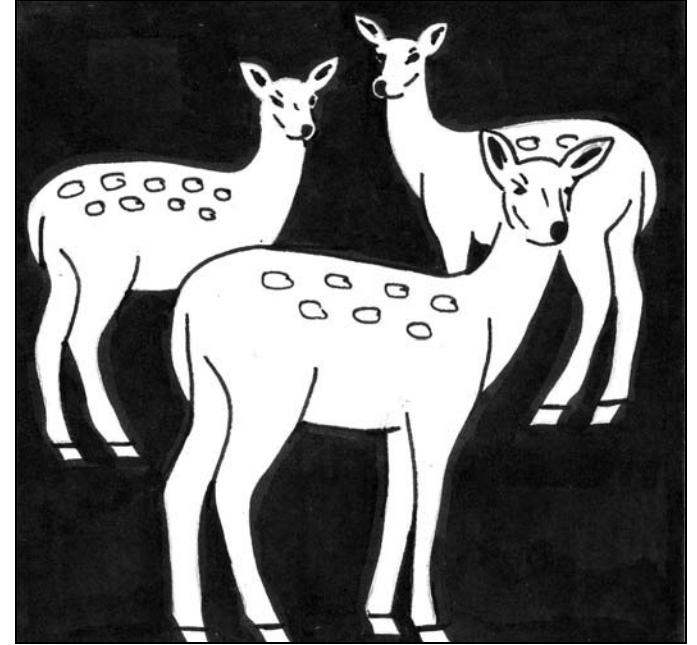
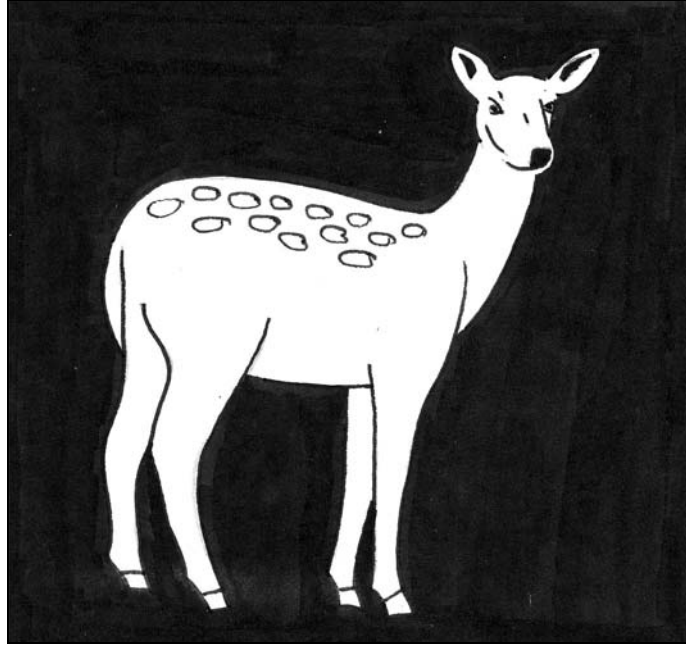
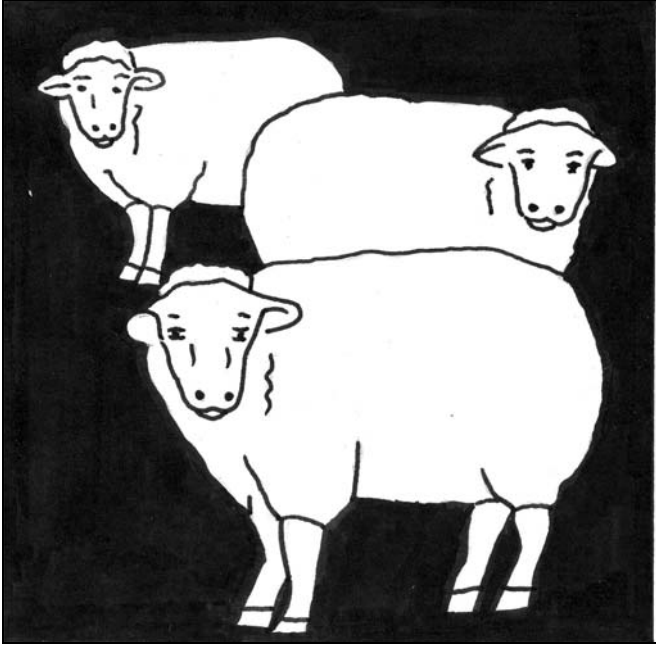

V cop 7.i A **the deer is white**; the deer are white; distractor: the sheep (pl.) are white

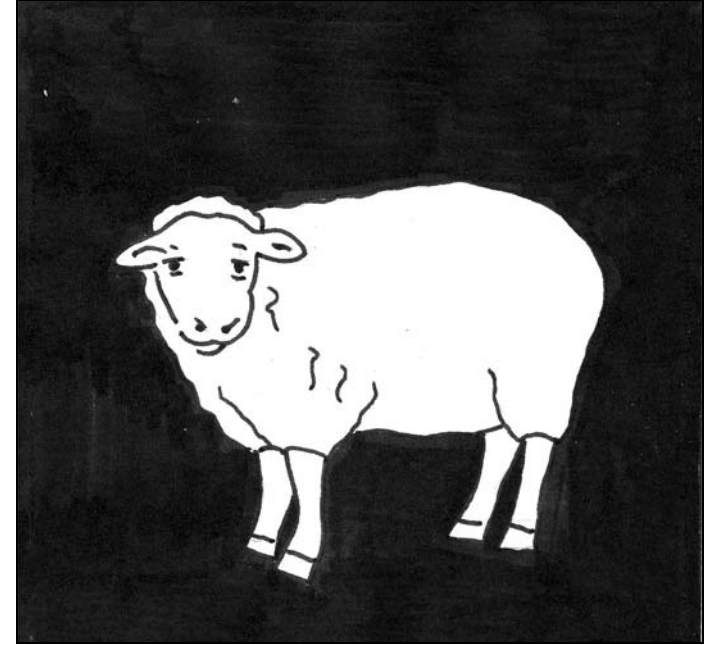
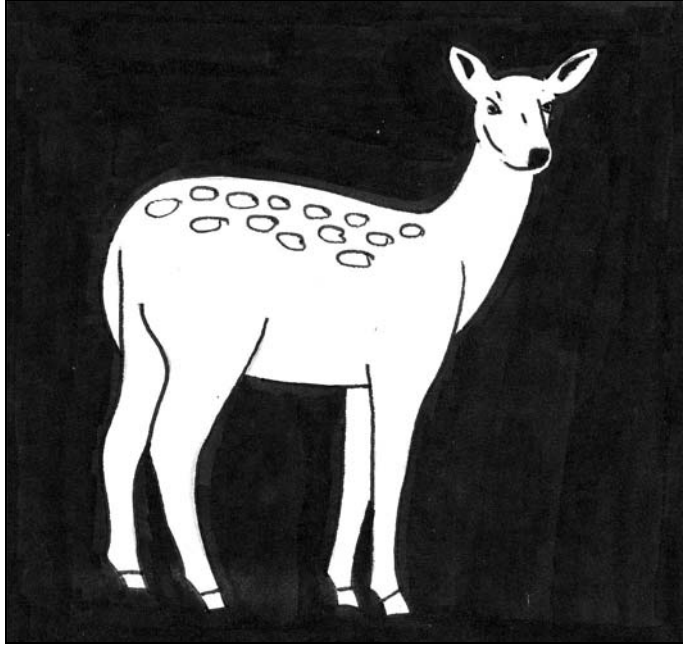
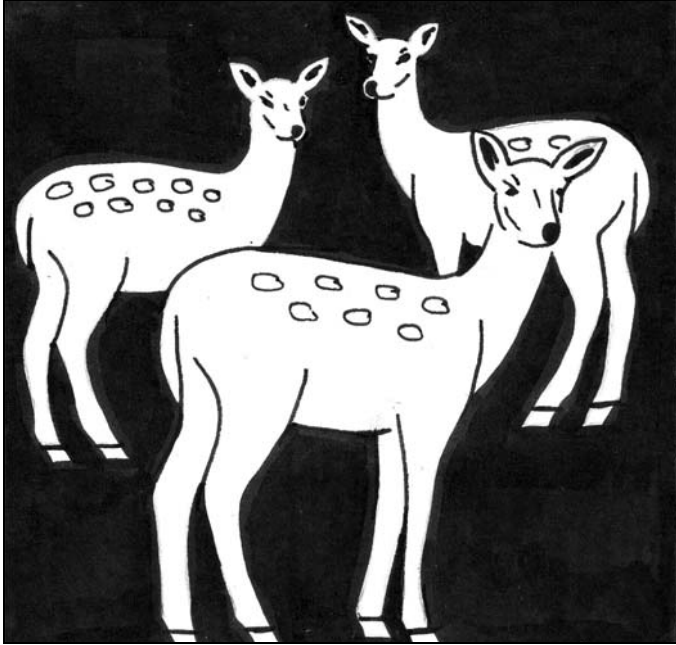

V cop 7.i B **the deer are white**; the deer is white; distractor: the sheep (sg.) is white

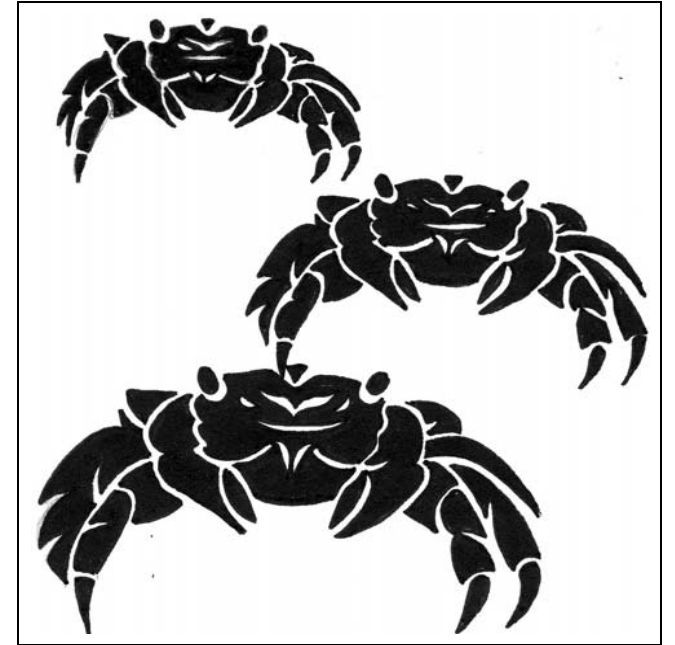
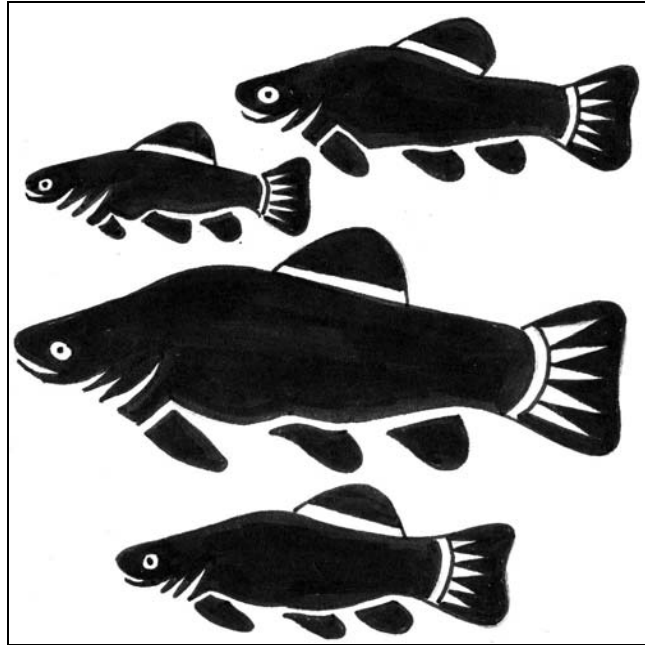
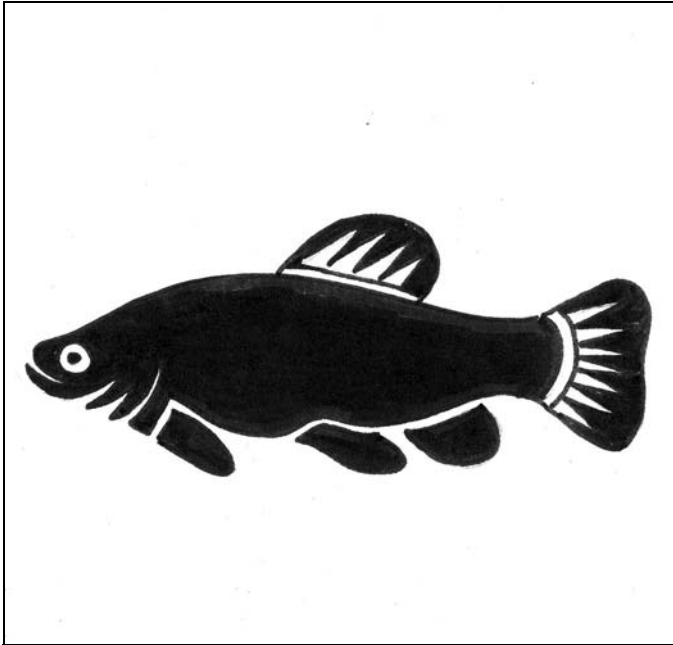

V cop 7.ii A **the fish is black**; the fish are black; distractor: the crabs (pl.) are black

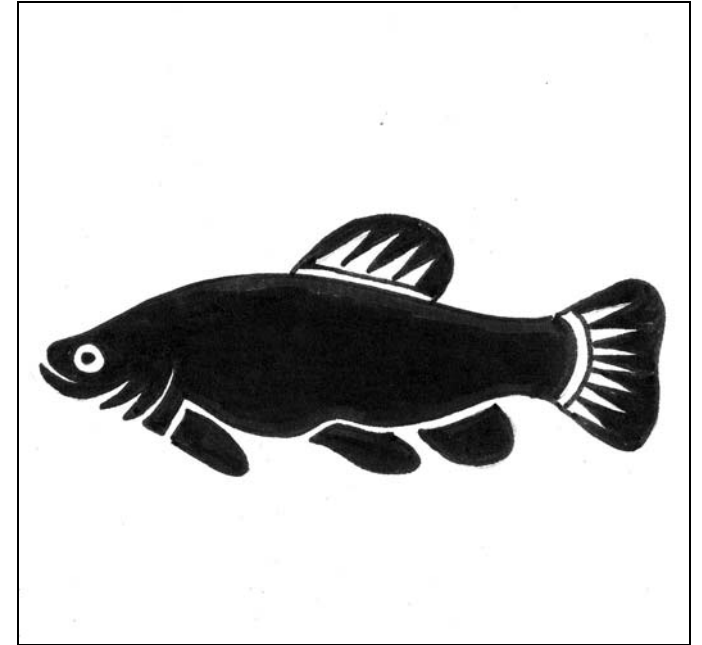
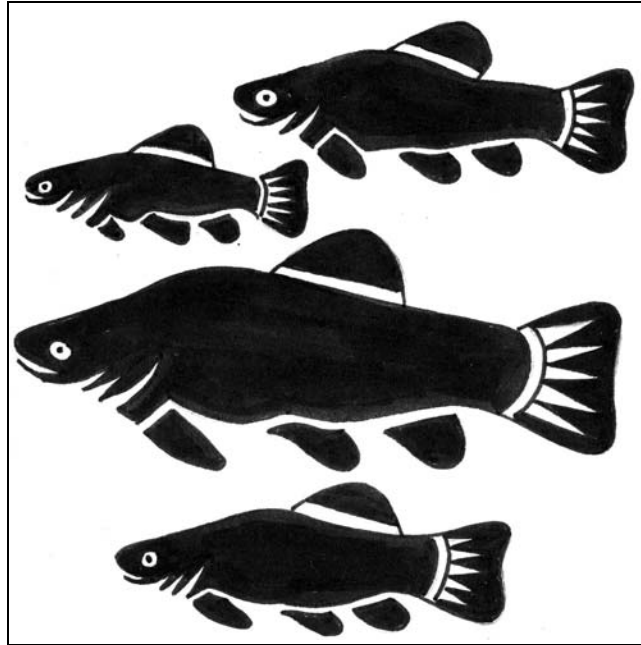
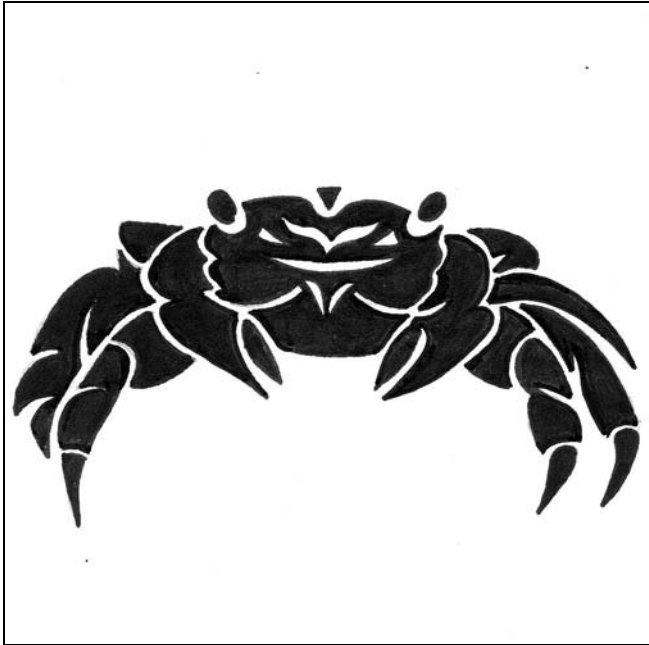

V cop 7.ii B **the fish are black**; the fish is black; distractor: the crab (sg.) is black

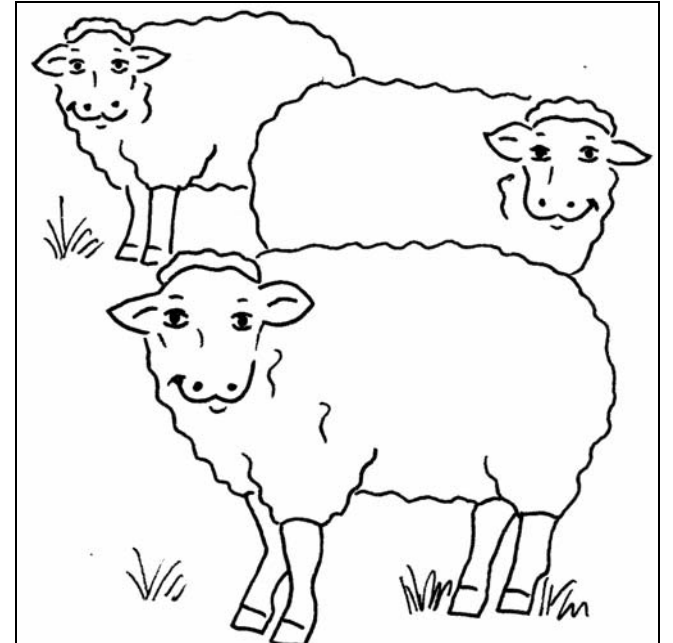
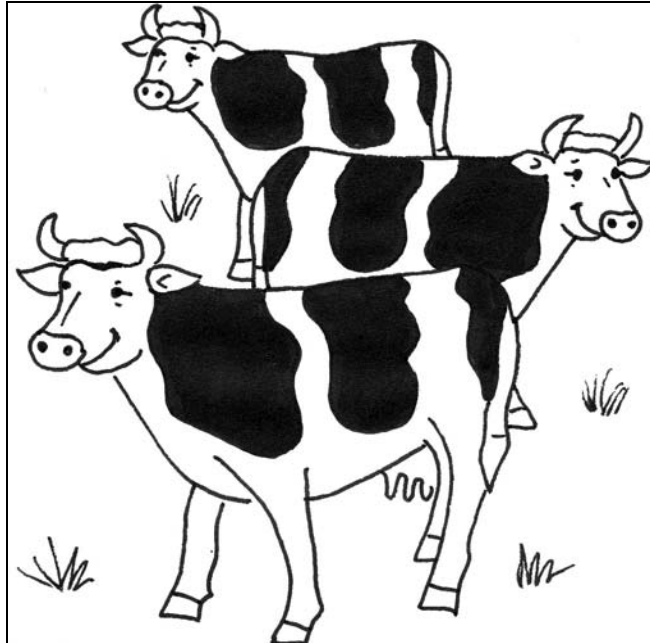
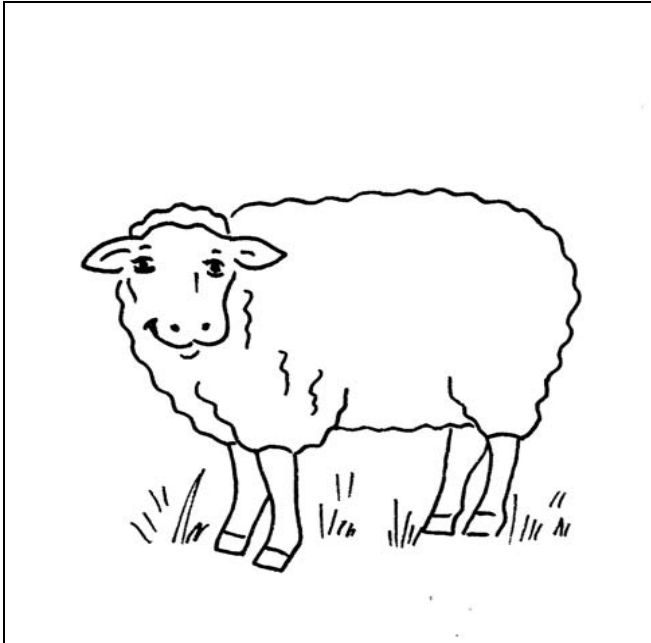

V cop 7.iii A **the sheep is happy**; the sheep are happy; distractor: the cows (pl.) are happy

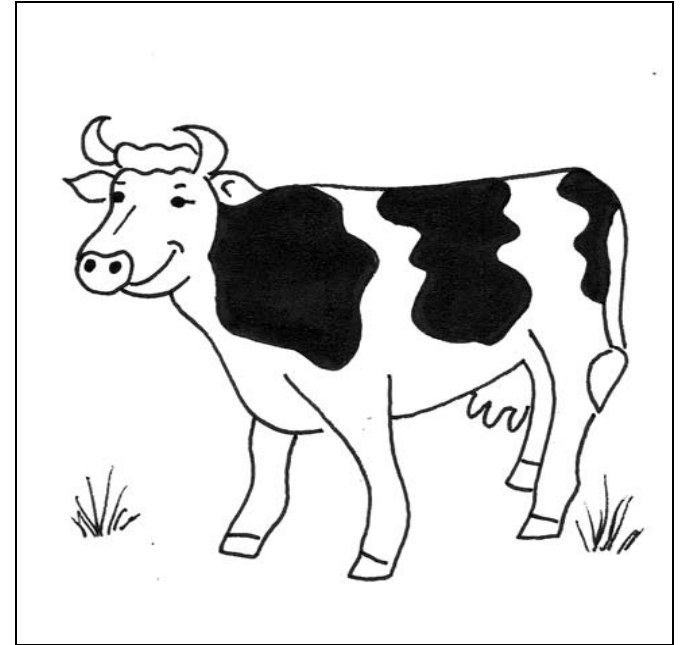
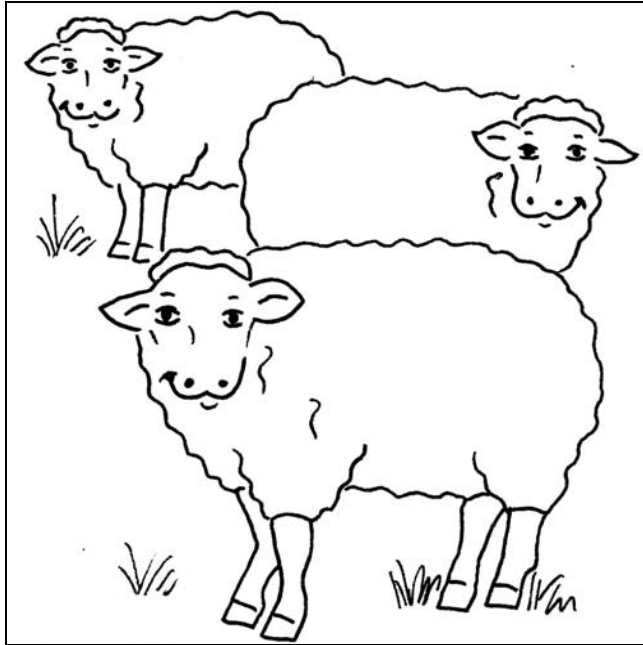
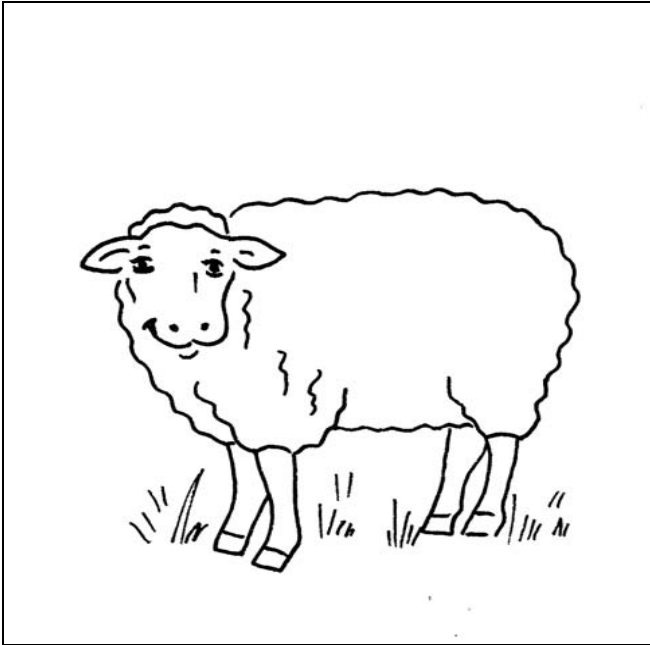

V cop 7.iii B **the sheep are happy**; the sheep is happy; distractor: the cow (sg.) is happy



Poss 8.i A, B: **the girl is kissing Tom; the girl is kissing Tom's dog**; distractor: everybody in the picture, no action

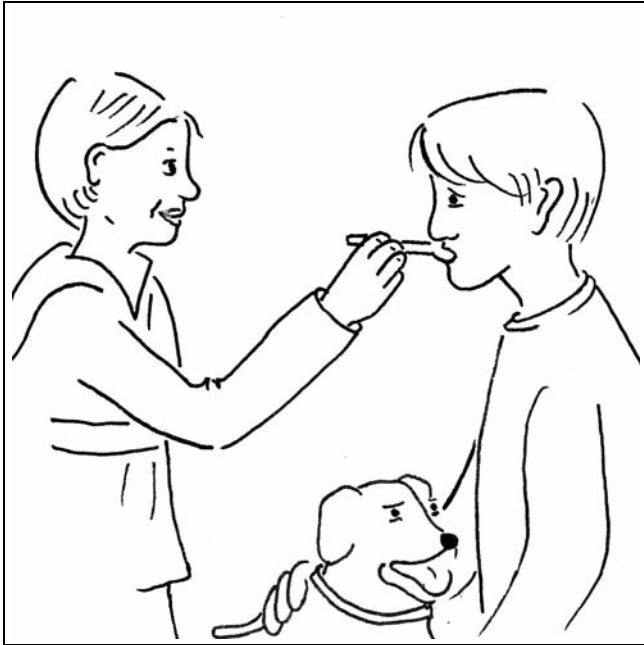

Poss 8.ii A, B: **the girl is feeding Tom; the girl is feeding Tom's dog**; distractor: everybody in the picture, no action



Poss 8.iii A, B: **the girl is carrying Tom; the girl is carrying Tom's dog**; distractor: everybody in the picture, no action



Pro m/f 9.i A, B: **he is singing; she is singing**; distractor: everybody in the picture, no action



Pro m/f 9.ii A, B: **he is drinking; she is drinking**; distractor: everybody in the picture, no action

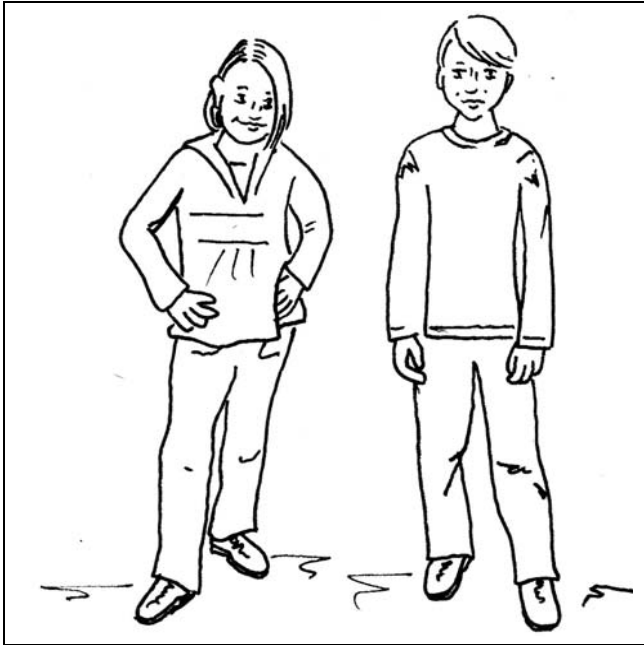

Pro m/f 9.iii A, B: **he is running**; **she is running**; distractor: everybody in the picture, no action



The ELIAS project has been funded with support from the European Commission.

Disclaimer:

This product reflects the views only of the authors, and the Commission cannot be held responsible for any use which may be made of the information contained therein.

Grant Agreement Number: 2008 - 3378 / 001 - 001

